

IVS

POWER CLEAN

The IVS brushing system in modular construction **flexible – rapid – efficient – open-ended**

Profile section:

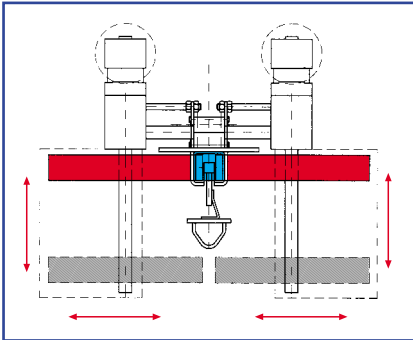

IVS-HR 2

Working area:

Horizontal
Radial

2 driven brushes

Top view:

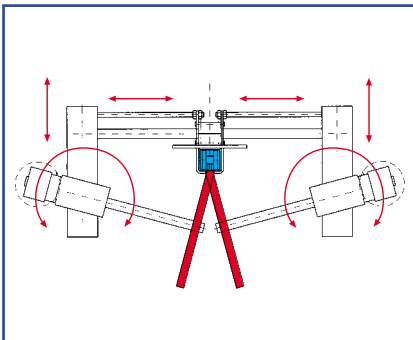
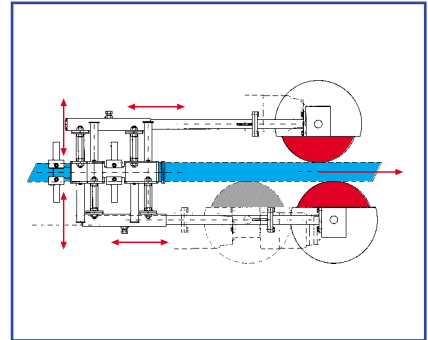

IVS-HR-S 2

Working area:

Horizontal
Radial
Continuously slewable

2 driven brushes

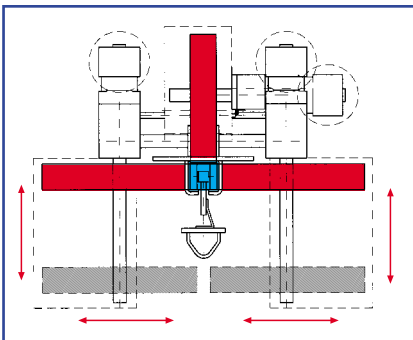
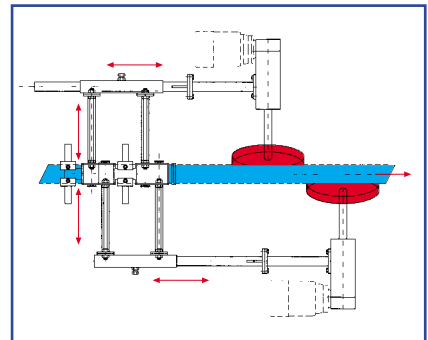

IVS-HRV 3

Working area:

Horizontal
Radial
Vertical

3 driven brushes

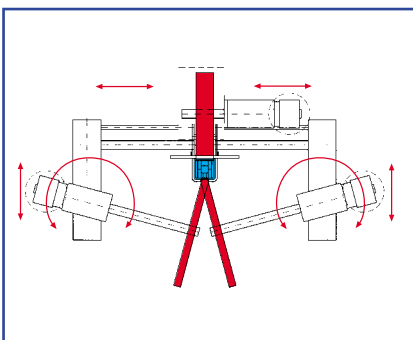
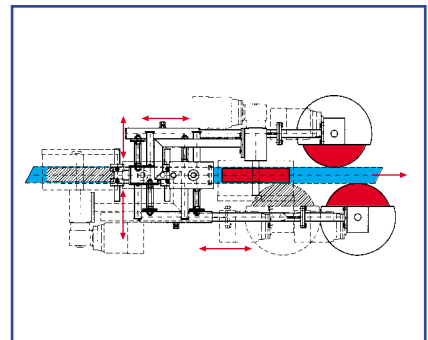

IVS-HRV-S 3

Working area:

Horizontal
Radial
Vertical
Horiz. continuously slewable

3 driven brushes

