

# Tube Sealing Unit TSE

Ultrasonic Sealing System for Tubes



# Ultrasonic Tube Sealing Unit TSE

Compact module for integration into filling lines

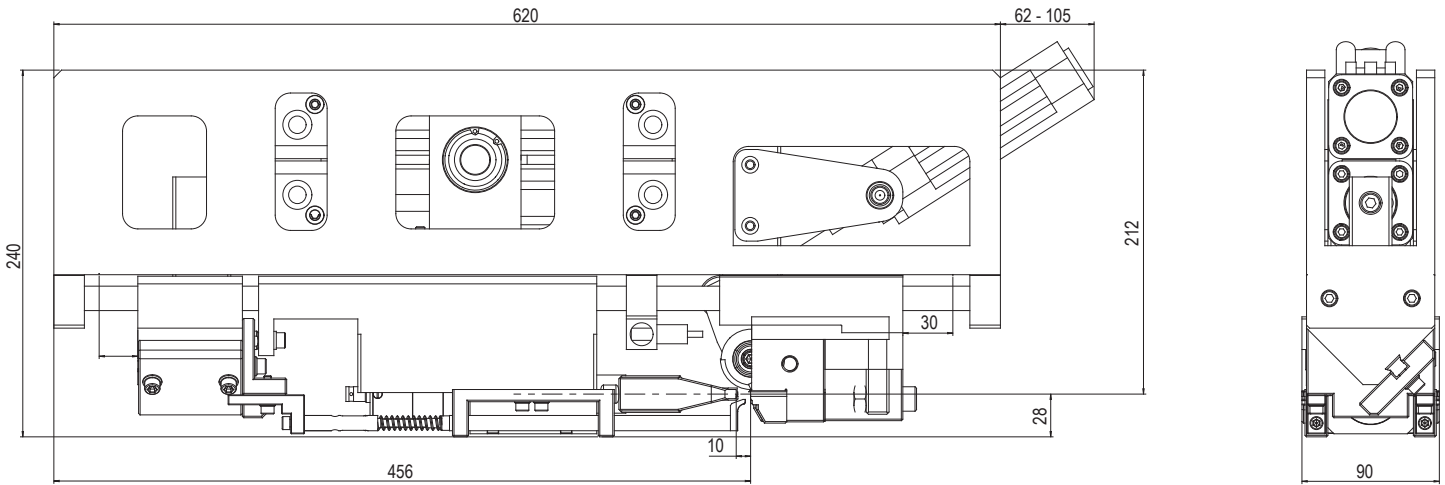

The completely redesigned Sonotronic tube sealing unit combines on request two functions in one module: Walled tubes and complex laminated structures can be tightly welded or sealed by the customized tool contours.

The optionally built-in cutting mechanism allows to cut the tube in the same position and in the same operation directly behind the weld. The very compact and slim unit can easily be strung together to form a multi-lane module system.

## Advantages

- Ultrasonic tools and sealing tongs from one source
- 35 kHz ultrasonic technology
- Common guidance system comprising the oscillating unit and anvil
- Sealing strength specifically adjustable
- Disturbing contours above tool level (not in the sealing area)
- Retention time specifically adjustable
- Optional cutting off the welding overlap in one station

## Technical data

Max. sealing width [mm]	90
Max. stroke [mm]	2 x 30
Max. closing force [N]	430
Number of cycles [cycles/min] at max. stroke	12
Max. air pressure [bar]	6
Reach on anvil side [mm]	164
Reach on sonotrode side [mm] at 35 kHz	456
Dimensions of sealing tongs W x H x D [mm]	90 x 240 x 620

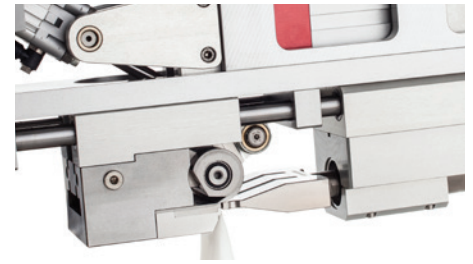

Ultrasonic tube sealing unit with cutting mechanism

## SONOTRONIC

Linked with success.

SONOTRONIC Nagel GmbH develops and produces high-tech ultrasonic systems and components for the packaging and food industries, as well as for medical engineering and textiles. We are the market leader in building special ultrasonic machines for

the car industry and in ultrasonic systems for environmental applications. We are a traditional company and employ more than 240 members at our headquarters in Karlsbad (Germany) and at our branches in Spain and the USA.



SONOTRONIC Nagel GmbH  
Headquarters  
Becker-Göring-Str. 17-25  
76307 Karlsbad, Germany  
Phone: +49 7248 9166-0  
Fax: +49 7248 9166-144  
info@sonotronic.de  
www.sonotronic.de

SONOTRONIC, Inc.  
Branch USA  
10338 Citation Drive, Suite 300  
USA-Brighton, MI 48116  
Phone: +1 810 2259030  
Fax: +1 810 2259037  
info@sonotronic.com